

hacona

S-type Impulse sealing machine

Instruction manual



Before using the machine please carefully read the instruction manual!

1. Foreword

1.1 Introduction

You have bought a machine with outstanding features and performance and we thank you very much for your confidence in choosing it. The HACONA system is unique in its kind. The technological development and quality of the components, as well as the materials used in the manufacturing and the testing process are the best guarantee of proper operation and long-lasting liability.

1.2 Performance of the packaging machine

Thanks to its particular operation circuit the machine, can be used both as bag making machine and as a plain sealing machine to seal the filled bags. You can use the following films manufactured and distributed by Hacona Ltd., LDPE, HDPE, PP, PVC, BOPP and any other laminated films that have a thermoplastic film inside. The maximum material thickness is between 10 - 500 μ . At the production of bags, the film can be perforated by running it through the perforating machine itself. The maximum capacity of the machine is up to 840 cycle/hour.

1.3 Machine identification

In every communication with the Manufacturer concerning the machine, always give the type and the serial number of the machine specified on the plate on the rear part of the machine.



1.4 Weight and dimensions of the packed machine

Type	Size [mm]			Weight [kg]
	A	B	C	
S-320 / SD-320	550	260	230	12,7 kg
S-420 / SD-420/ SI-420	650	260	230	14,1 kg
S-620 / SD-620/ SI-620	850	260	230	18,2 kg
S-820 / SD-820	1050	260	230	23,9 kg
S-1020 / SD-1020	1250	260	230	26,7 kg

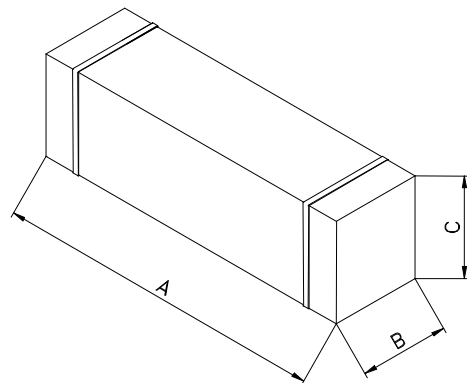

1.5 Machine weight and dimensions without mounting

Type	Size [mm] a x b x c	Weight [kg]		
		SI	S	SD
S- 320 / SD- 320	490 x 209 x 210	-	11.7	12.7
SI-420 / S- 420 / SD- 420	590 x 209 x 210	13.0	13.0	14.0
SI-620 / S- 620 / SD- 620	790 x 209 x 210	16.7	16.7	17.7
S- 820 / SD- 820	990 x 209 x 210	-	22.4	23.4
S-1020 / SD-1020	1190 x 209 x 210	-	25.2	26.2

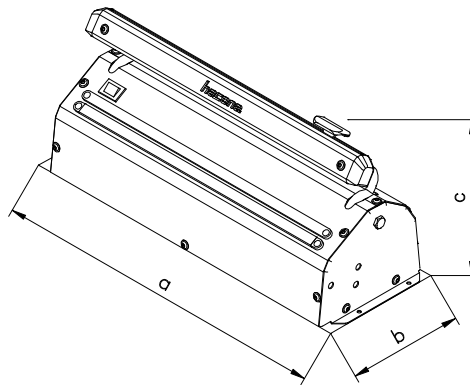

1.6 Machine weight and dimensions with mounting

Type	Size [mm] a x b x c	Weight [kg]		
		SI	S	SD
S- 320 / SD- 320	520 x 650x 1100	-	24	25
SI-420 / S- 420 / SD- 420	620 x 650 x 1100	28	28	29
SI-620 / S- 620 / SD- 620	820 x 650 x 1100	34	34	35
S- 820 / SD- 820	1020 x 650 x 1100	-	40	41
S-1020 / SD-1020	1220 x 650 x 1100	-	46	47

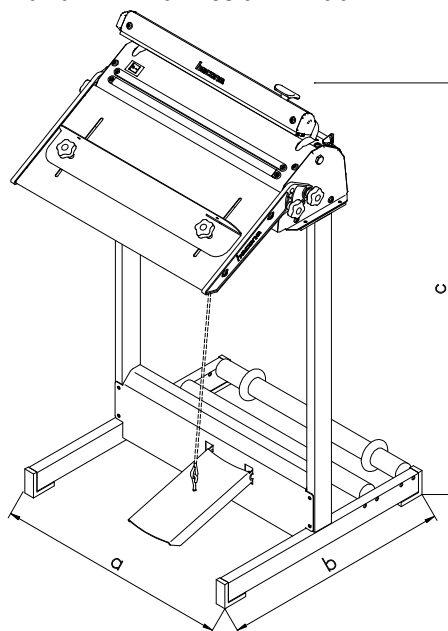

2. Machine installation

2.1 Transport and positioning of the machine

Handle the machine with the greatest care at transport and positioning. Cut the strap with scissors and remove the machine out of the carton box. The machine has to be placed in dry and well ventilated room on stable floor, so that the working flow is not impeded.

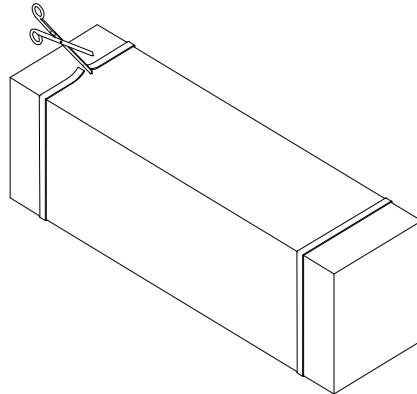

2.2 Environmental conditions

Place the machine in a suitable environment, free from humidity, gases, explosives and combustible materials.

Working environmental conditions:

Temperature from +5°C to +40°C

Relative humidity from 30% to 90%, without condensation.

2.3 Electrical connection

OBSERVE HEALTH AND SAFETY REGULATIONS !
GROUNDING OF THE UNIT IS OBLIGATORY

Before executing electrical connections, make sure the mains voltage matches the one on the plate on the back part of the machine and the grounding contact complies with the safety rules in force. In case of doubts concerning the mains voltage, contact the local public Electric Works.

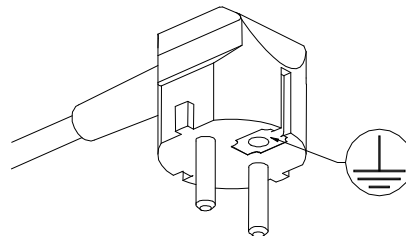

2.4 Machine installation

2.4.1 Mounting of the machine with support

Fit the machine on the mounting, as it is shown on the enclosed drawing. Take good care at the mounting, tighten up all the four screws very well. Screw the machine with all the four screws tight to the support.

Assembling the support →

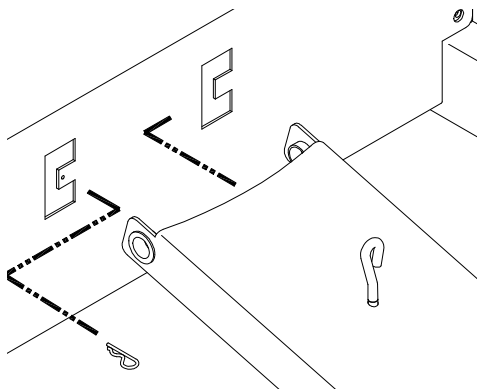
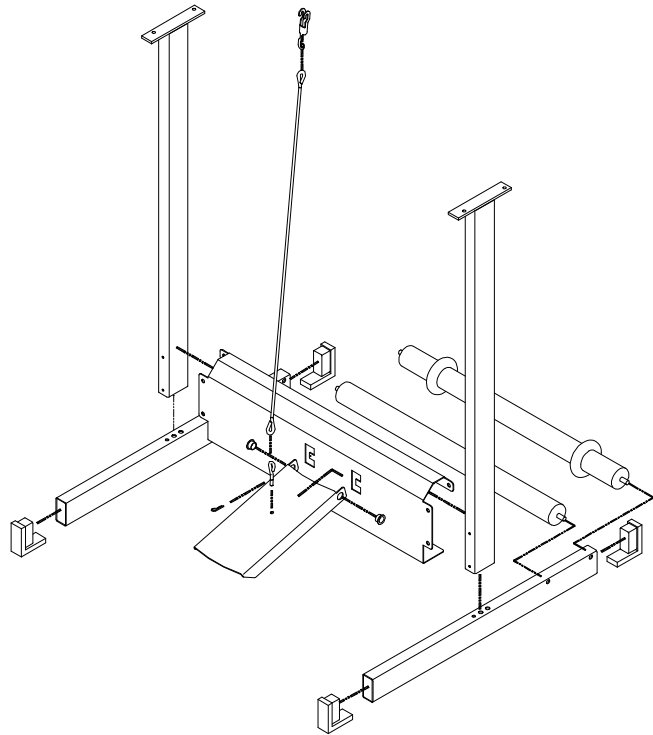

Engaging the foot pedal

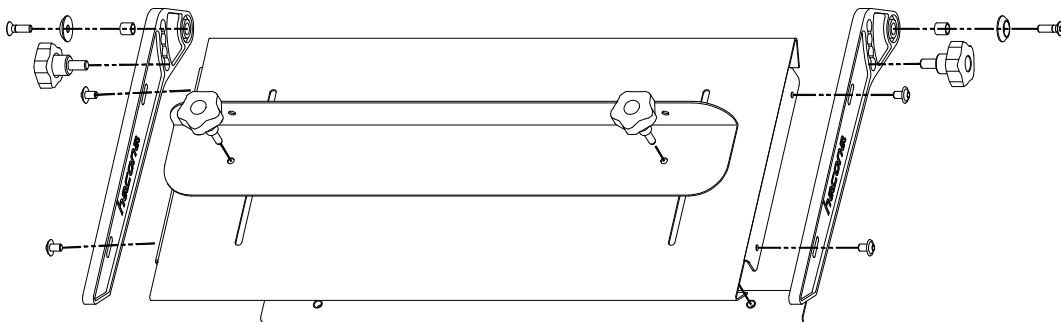
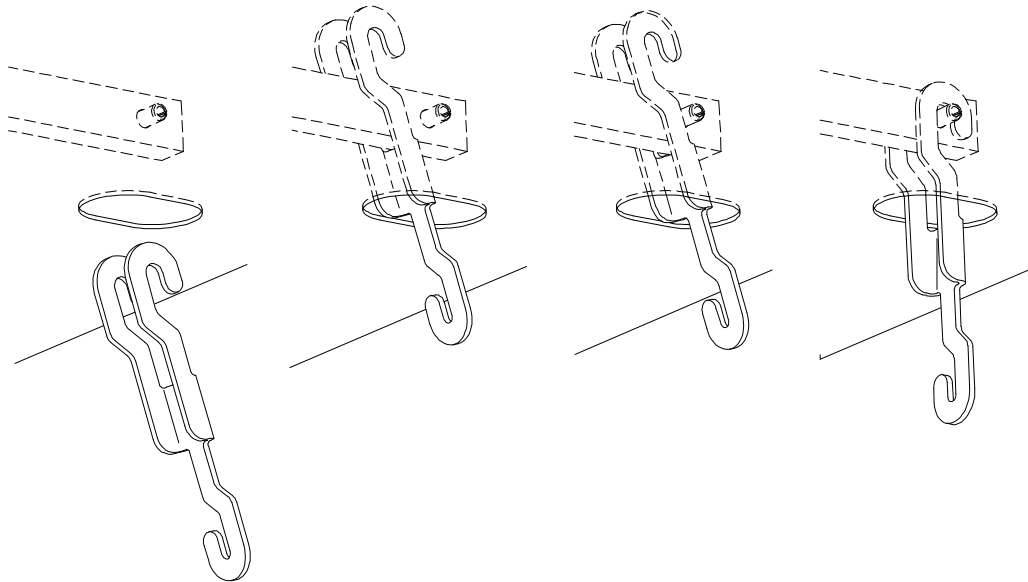

Table assembling

The hook, which connects the chain to the machine, has to be hooked in from below the machine through the oval hole. You can see the pulling rod from below, when you close the sealing bars manually. With the help of the chain connect the machine with the foot pedal. The length of the chain has to be adjusted so that when the sealing bars are closed, the distance between the foot pedal and the floor is not more than 1 cm.



2.4.2 Mounting of the machine without support

Screw the machine on to the table, so that the front edge of the machine has to be about 5 cm ahead of the table edge. This way you can connect the chain of the pedal to the machine. The hook, which connects the chain to the machine, has to be hooked in from below the machine through the oval hole. You can see the pulling rod from below, where the hook will be hooked on, when you close the sealing bars manually. It is recommended to screw the mobile foot pedal with screws to the floor. With the chain connect the machine with the foot pedal. The length of the chain has to be adjusted, so that when the sealing bars are closed the distance between the foot pedal and the floor is not more than 1 cm.

3. Machine adjustment and setting up

3.1 Regulation

The machine has its main switch on the front part of the machine on the left side. To turn on the machine place the rocker switch in the „-“ position. The SD switch on the right side switches on the second filament. This way a much safer closing is achievable.

Note: If ON, the rocker switch shines red.

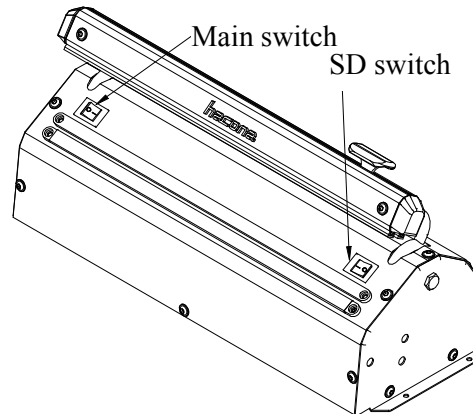

The machine has 2 potentiometer on the left side:

1. To adjust the sealing time
2. To adjust the cooling time

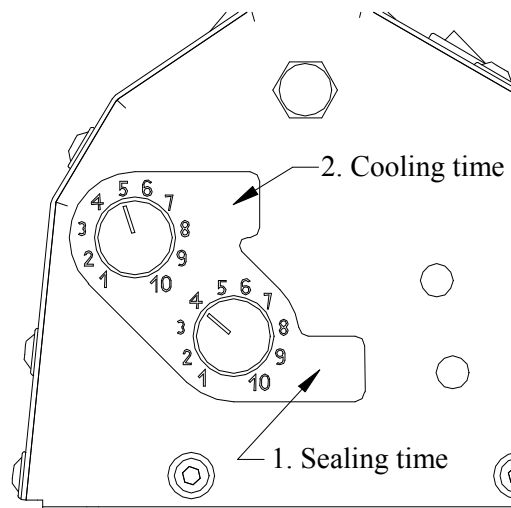

The proper sealing time depends on the thickness and the kind of the packing film. To make a sealing test you have to adjust the sealing- and cooling time on to value 3. Place the bag between the sealing bars and then operate the machine by closing the sealing bar by hand or by foot pedal. The built-in electro magnet observes the needed pressure, and keeps the sealing bar closed during the adjusted sealing- and cooling time.

If the bag is not sealed properly (the bag stays open), raise the sealing- and cooling time. If the bag melts along the sealing, lower the sealing- and cooling time. Always begin the test sealing with low values, and raise them if necessary in small steps.

Note: It is recommended to adjust the cooling time on the same level as the sealing one, or higher than the sealing time. This way you receive a very strong sealing

Attention:



Never adjust the cooling time below value 1. Otherwise the Teflon, sealing wire and the transformer will worn out too soon as they do not get enough cooling time.

3.2 Functioning of the cutting knife

The cutting knife is equipped with a safety device. Through pushing the top of the cutting head and moving the cutting sledge to left or right, it is possible to cut of the redundant film and also to produce bags out of tube film..

Note: You get the best cutting result, if the cutting head is pushed down in the middle of the film and then moved left and right.

Explanation: This way you can prevent the film from tearing on the sides during the sealing.

!!! ATTENTION DANGER !!!

Attention:



Never operate the cutting device (push the cutting head down and move it left and right) when the sealing bar is open!!! Each time before the machine will be used check if there is no damage on the cutting device and if the cutting knife is on its proper position!

3.3 Positioning the film reel

Place the film reel on the middle of the two film reel holding rollers (option), which are

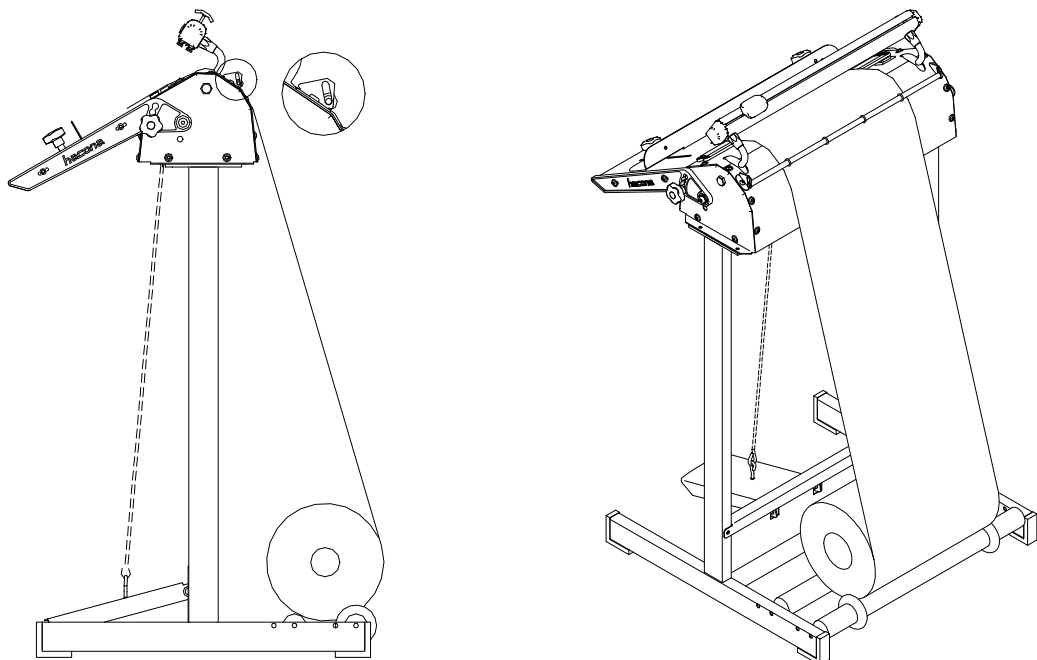

located on the back of the support. Adjust the two rubber rings to the side of the film reel, so that the film role always stays in the same position. Pull up the film on the back of the

machine and lead it through under the film stop (option). If the machine is equipped with micro puncher it is possible to perforate the film by leading it through the micro puncher.

3.4 The use of the worktable and bag support (option)

The angle of the worktable can be adjusted in 8 positions (horizontal to almost vertical). It is possible to adjust the worktable by turning out the knobs on both sides, and after the adjustment turning them back again. The position of the bag support is infinitely variable. Attention: the position of the bag support always has to be parallel to the sealing.

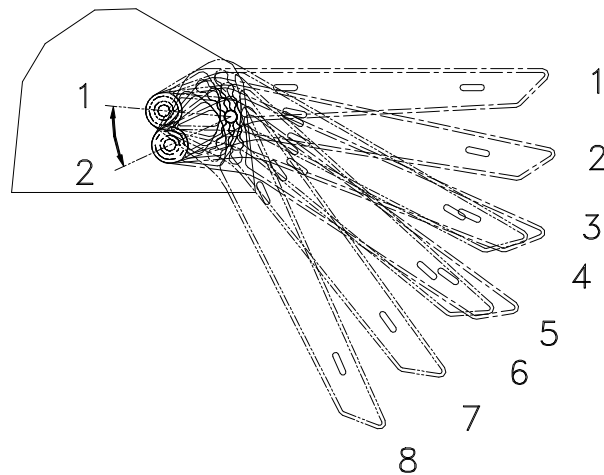

4. Conditions and limits in the use of the machine

4.1 Max. pack sizes

Type	Max. film width
S-320	320 mm
SD-320	320 mm
S-420	420 mm
SD-420	420 mm
SI-420	420 mm
S-620	620 mm
SD-620	620 mm
SI-620	620 mm
S-820	820 mm
SD-820	820 mm
S-1020	1020 mm
SD-1020	1020 mm

There are no limitations on the length of the film.

4.2 Items which cannot be packed



It is strictly prohibited to pack the below listed products, to avoid damages to the machine and serious injuries to the operator in charge: Wet and unstable products, liquids of any kind, flammable and explosive materials and any other materials and products not listed but which might harm the operator and cause damages to the machine.

5. Films to be used

5.1 Films to be used

Machine can work with all films with thickness 10 - 500 μ (2x250 μ) manufactured or distributed by "Hacona Kft". The special features of our films (customized with logo, drawings and text) assure their outstanding reliability, with regard both to compliance with laws in force and to an excellent machine performance.

With the machine the following films can be sealed:

PE, PP, PO, PVC, BOPP and any other laminated film which have a thermoplastic layer inside, as well as all thermoplastic films.

6. Safety standards

6.1 Warnings

Attention:



Immediately after sealing it is strictly prohibited to touch the sealing wire. It is possible to get serious by burnt!



Never operate the machine with broken sealing wire. In this case you have to change immediately the sealing wire and the Teflon cover!



Check whether the machine is screwed properly to the table or the support!



Check for each use, if there is no damage on the cutting device and that the cutting knife is in the proper position!



Check if the film roll is in the proper position!

7. Ordinary maintenance

7.1 Precautions for ordinary maintenance interventions



BEFORE PROCEEDING TO MAINTENANCE, SWITCH THE MACHINE OFF AND DISCONNECT IT!

7.2 Cleaning

The machine does not need any special cleaning. Remove any scraps stuck on to the sealing area. Use a slightly wet cloth for the cleaning of the machine. It is recommended to use a normal glass detergent. Do not use detergents which contain solvent.

Attention:



For each cleaning it is necessary to turn off the machine and pull the electric connection from the power supply!

7.3 The changing of the spare parts

7.3.1 How to change Teflon and sealing wire

If the Teflon cover and/or the sealing wire of the sealing bar is damaged or broken it has to be replaced.

Unscrew the two screws on both ends of the sealing bar (A) and lift out the sealing bar of the machine. Loosen the electrical connection on both ends (B) by pulling off the plug connection from the sealing bar. Hang the two wires in the small slide in the hole (C), so that the wires cannot fall into the machine.

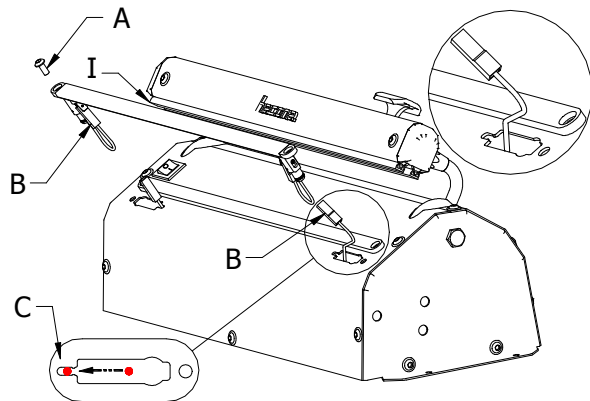

Remove the damaged Teflon (D), sealing wire (E) and the lower adhesive Teflon (F) from the aluminium bar.

Replace the adhesive Teflon with a new one (F).

Attention:



The adhesive Teflon (F) has to be 4 mm longer than the aluminium bar on both sides. This way you can avoid a short-circuit!

Push the piston into the tightening system and place the new sealing wire into the piston and fix the sealing wire with the two grub screws.

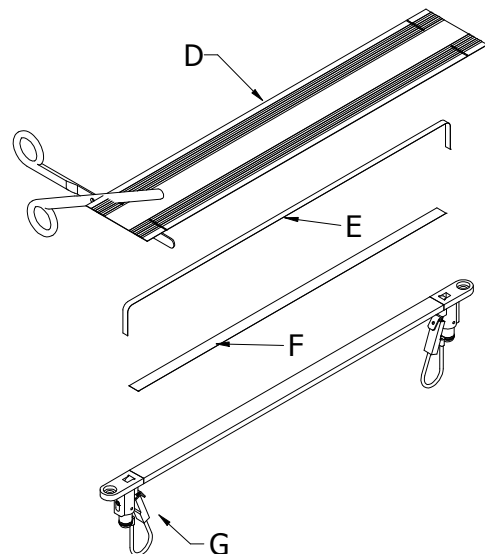

Cutting length

	Silicon rubber	Sealing wire	Teflon pad	Teflon cover
S-320	405 mm	390 mm	326 mm	360 mm
S-420	505 mm	490 mm	426 mm	460 mm
S-620	705 mm	690 mm	626 mm	660 mm
S-820	905 mm	890 mm	826 mm	860 mm
S-1020	1105 mm	1090 mm	1026 mm	1060 mm
		5 x 0.1 mm	Adhesive Teflon stripe 10 mm wide	40 mm brown, adhesive stripes on the margin

Push the piston (K) into the tightening system (G) at both ends of the sealing bar and drift the fixing pins (L) through the pre-drilled bore. By doing so the piston (K) is properly prestressed..

Introduce the sealing wire (E) in the piston (K) and fix it with the grub-screws (H). After this remove the fixing pins (L).

Attention:

If no fixing pins are available, proceed as follows:



The sealing bar is equipped with a tightening system (G). Before the tightening of the second screw (H) the piston of the tightening system (G) has to be pushed in manually!

The fibreglass reinforced upper Teflon (D) which has adhesive stripes on both sides has to be cut on the length of the sealing bar. Stick one side of the Teflon (D) to the bottom of the sealing bar (E). Wind the Teflon around the sealing bar, so that the Teflon cover tightens the sealing bar. Stick the other side of the Teflon to the same place (bottom of the sealing bar).

Note: On the tightening system, if it is necessary, cut in the tape on both sides of the Teflon in order to fit it perfectly onto the sealing bar.

Attention:



Use only original spare parts from Hacona!

It is not allowed to use fully backed adhesive Teflon as upper foil, because the sealing wire tightening system cannot work properly, and out of this reason the sealing wire gets ruined immediately or very quickly.

Note: If the upper Teflon (D) is burnt through, it can happen that the silicon rubber (I) is also damaged. Please check if there is no damage on the silicon rubber, and replace if necessary.

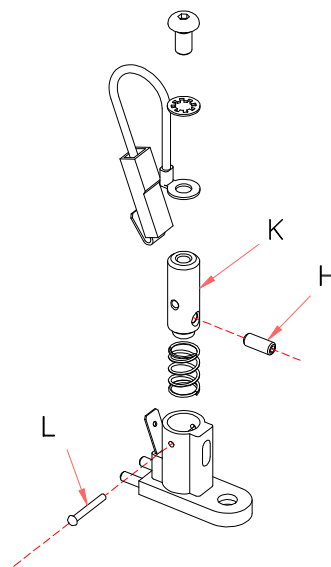

7.3.2 How to change the silicon rubber

Pull the damaged or burnt silicon out of the upper sealing bar, and replace it with a new one.

Attention! Caution when you change the silicon, watch out for the cutting knife!

THERE IS A DANGER OF CUTTING.

Attention! Use only original spare parts from HACONA!

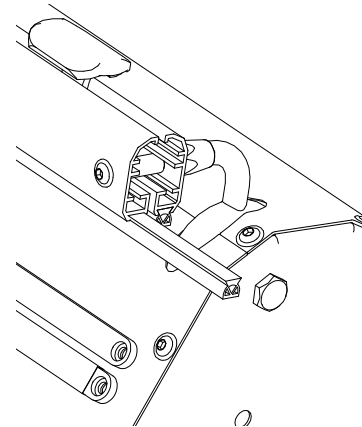

7.3.3 How to change the cutting knife

Is the cutting knife damaged or blunt, you have to change it by pushing down the head of the cutting sleigh and remove the old knife by pulling it out of its original place with pincers.

Attention! At the change of the cutting knife there is a high risk of cutting injury!!!

Always use safety gloves !!!

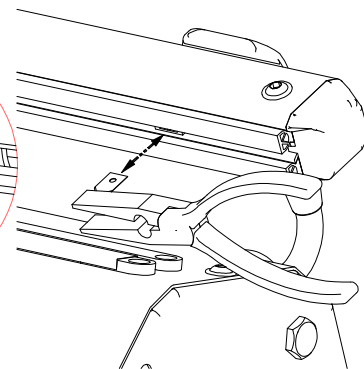
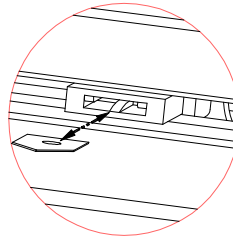

Attention!



Use only original spare parts from “Hacona”

7.3.4 How to change the cutting sleigh

Is the cutting sleigh worn or damaged, you have to change it by a new one. Remove the black plastic cap from one side of the upper sealing bar. Loosen up the screw on the front of this side, which holds the two aluminium profiles together. Remove the distance holder between the two aluminium profiles. Pull out the old cutting sleigh on this side.

Replace the new cutting sleigh the same way into the upper sealing bar, only the opposite way.

Attention! Use only original spare parts from Hacona!

ATTENTION VERY IMPORTANT!



At each change of spare parts use only original “Hacona” spare parts!

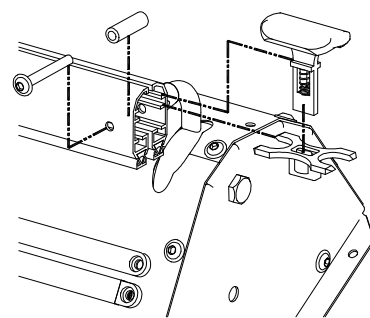

7.4

Wiring diagram

S-320 / S(I)-420 / S(I)-620

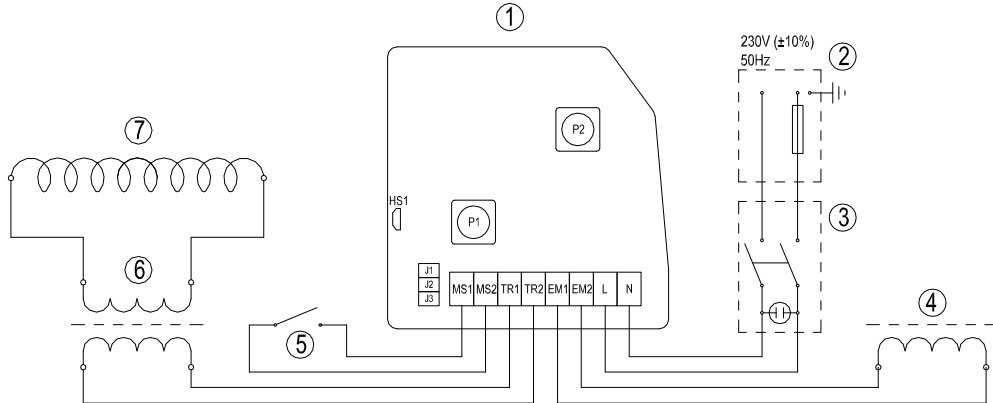

- | | |
|---|---|
| 1: Control panel | 7: Sealing bar |
| 2: Power outlet / fuse | J1-J2-J3: Jumper for choosing from micro switch, or Hall sensor mode |
| 3: Main power switch / 1.v.glow lamp | HS1: Integrated Hall sensor (To use this, you have to connect the J2 and J3 with a jumper.) |
| 4: Electro magnet | P1: Integrated potentiometer (sealing time) |
| 5: Micro switch (To use this, you have to connect the J1 and J2 with a jumper.) | P2: Integrated potentiometer (cooling time) |
| 6: Transformer | |

S-820 / S-1020

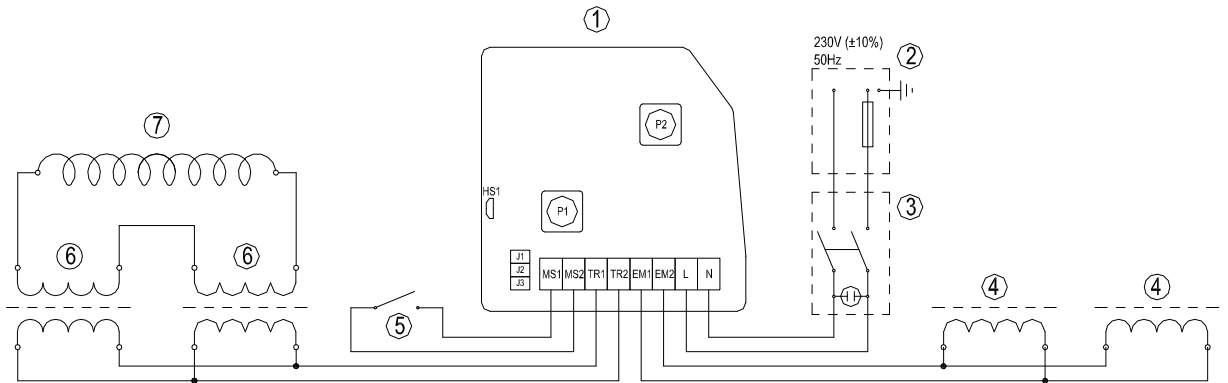

- | | |
|--|---|
| 1: Control panel | 7: Sealing bar |
| 2: Power outlet / fuse | J1-J2-J3: Jumper for choosing from micro switch, or Hall sensor mode |
| 3: Main power switch / 1.v.glow lamp | HS1: Integrated Hall sensor (To use this, you have to connect the J2 and J3 with a jumper.) |
| 4: Electro magnet | P1: Integrated potentiometer (sealing time) |
| 5: Micro switch (To use this, you have to connect the J1 and J2 with a jumper.)! | P2: Integrated potentiometer (cooling time) |
| 6: Transformer | |

S(I)D-420 / S(I)B-420 / S(I)D-620 / S(I)B-620

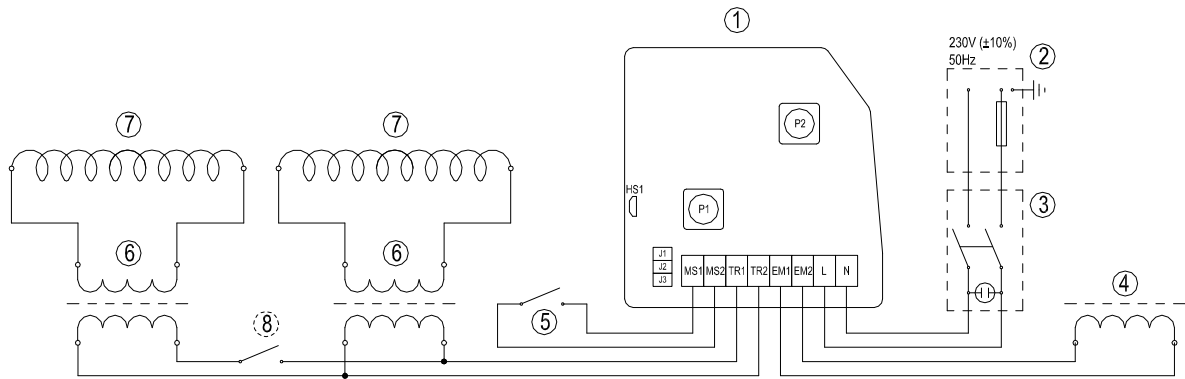

- 1: Control panel
- 2: Power outlet / fuse
- 3: Main power switch / 1.v.glow lamp
- 4: Electro magnet
- 5: Micro switch (To use this, you have to connect the J1 and J2 with a jumper.)!
- 6: Transformer
- 7: Sealing bar
- 8: SD switch (SD machine only)
- J1-J2-J3: jumper for choosing from micro switch, or Hall sensor mode
- HS1: Integrated Hall sensor (To use this, you have to connect the J2 and J3 with a jumper.)
- P1: Integrated potentiometer (sealing time)
- P2: Integrated potentiometer (cooling time)

SD-820 / SB-820 / SD-1020 / SB-1020

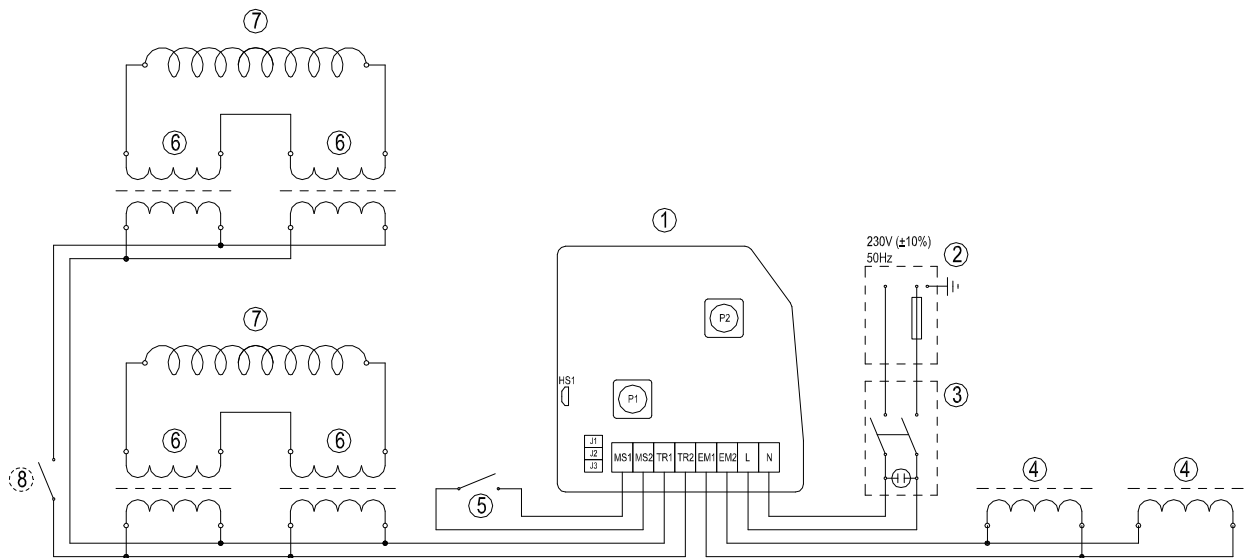

- 1: Control panel
- 2: Power outlet / fuse
- 3: Main power switch / 1.v.glow lamp
- 4: Electro magnet
- 5: Micro switch (To use this, you have to connect the J1 and J2 with a jumper.)!
- 6: Transformer
- 7: Sealing bar
- 8: SD switch (SD machine only)
- J1-J2-J3: jumper for choosing from micro switch, or Hall sensor mode
- HS1: Integrated Hall sensor (To use this, you have to connect the J2 and J3 with a jumper.)
- P1: Integrated potentiometer (sealing time)
- P2: Integrated potentiometer (cooling time)

7.5

Wearing parts

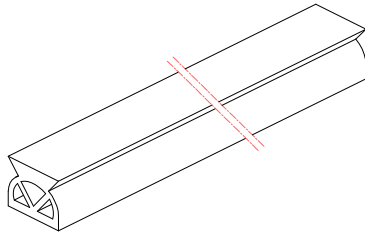

Silicon rubber

S-320 / SD-320	001-094
S-420 / SD-420 / SI-420	001-095
S-620 / SD-620 / SI-620	001-096
S-820 / SD-820	001-097
S-1020 / SD-1020	001-098

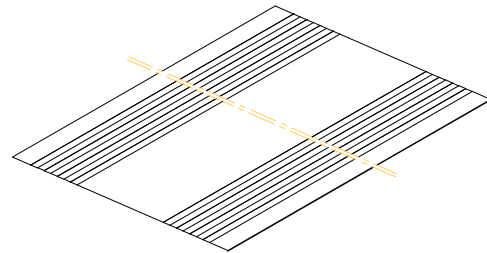

Teflon cover

S-320 / SD-320	001-129
S-420 / SD-420 / SI-420	001-130
S-620 / SD-620 / SI-620	001-131
S-820 / SD-820	001-132
S-1020 / SD-1020	001-133

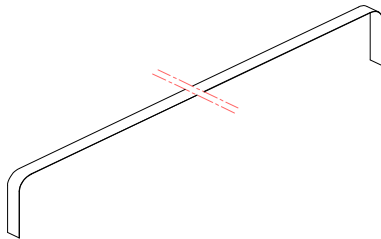

Sealing wire

S-320 / SD-320	001-117
S-420 / SD-420 / SI-420	001-118
S-620 / SD-620 / SI-620	001-119
S-820 / SD-820	001-120
S-1020 / SD-1020	001-121

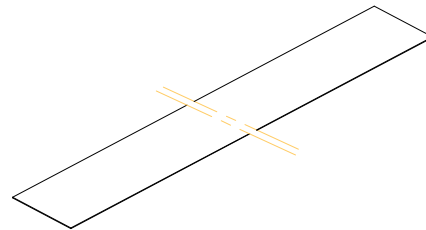

Adhesive Teflon pad

S-320 / SD-320	001-135
S-420 / SD-420 / SI-420	001-136
S-620 / SD-620 / SI-620	001-137
S-820 / SD-820	001-138
S-1020 / SD-1020	001-139

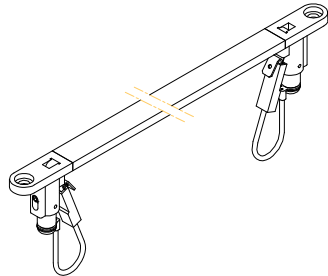

Sealing bar / electrode

S-320 / SD-320	001-140
S-420 / SD-420 / SI-420	001-141
S-620 / SD-620 / SI-620	001-142
S-820 / SD-820	001-143
S-1020 / SD-1020	001-144

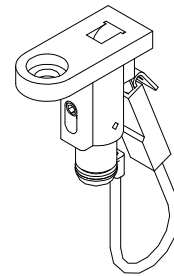

Tightening system

(all types) S-... / SD-... / SI-...	001-380
-------------------------------------	---------

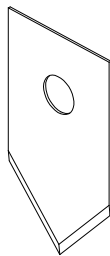

Cutting blade

(all types) S-... / SD-... / SI-...	001-090
-------------------------------------	---------

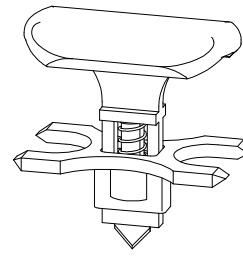

Cutting blade holder

(all types) S-... / SD-... / SI-...	001-093
-------------------------------------	---------

7.6 Disassembling of the machine and the elimination of waste material

Attention!



All operations about disassembling must be done by qualified personnel with mechanical and electrical expertise required to work in security conditions.

Process as follows:

1. Disconnect machine from power supply.
2. Disassemble components.

All wastes must be treated, eliminated or recycled according to their classification and to the procedures in force established by the laws in force in the county the equipment has been installed.

8. Guarantee

8.1 Certificate of guarantee

The guarantee runs for 12 month after the date of purchase under the conditions set forth on the instruction manual. Fill in the warranty with all data requested, tear out along the perforation and send it back to the manufacturer.

8.2 Guarantee conditions

The guarantee runs for 12 month and goes into force on the date of purchase of the machine. The guarantee covers free replacement or repair of any parts due to defects arising from faulty material. The repairs or replacement are usually carried out at the manufacturers, with transport or workmanship at buyer's charge. If the repair or replacement is carried out at the buyer's place, he shall bear the traveling, transfer and workmanship charges. Work under guarantee can be carried out exclusively by the manufacturer or by the authorized dealer. In order to be entitled to repairs under the guarantee the damaged component has to be sent back to the manufacturer or its authorized dealer for replacement or repairing.

The guarantee is voided:

- In case of failure to mail the CERTIFICATE OF GUARANTEE, duly filled in and signed within 20 days after the date of purchase.
- In case of inappropriate installation, power supply, misuse and mishandling by unauthorized people.
- In case of changes made to the machine without prior agreement in writing by the manufacturers
- If the machine is no longer in the property of the first buyer.

Hacona Ltd is legally entitled to decline any responsibility for damage to people or things in case of inappropriate installation or connection to the power mains or omissions of connections to earth or in case of any mishandling of the machine. The manufactures undertake to carry out any variations and changes made necessary by technical and operating requirements.



Attention!

The guarantee is not valid for wearing part!

9. EC declaration of conformity

Wir: Hacona Kft
H-1165 Budapest
Újszász u. 45/B
(Hungary)

declare under our responsibility that the product:

Impulse sealing machine

Type:

Serial No.:

Is in conformity with provision of following directives and their modifications:

98/37/CE
89/336/CEE
73/23/CEE.

Furthermore we declare that the following rules have been applied:

EN 292-2:1993
EN 292-2:1991/A1:1997
EN60204-1:1995
EN 60204-1

Budapest, / /

Dipl. Ing. L. Nagy
Managing Director